

MASTER
Chef™™

**GRILL
TURISMO**™™
22" (55.9 CM) PORTABLE
GAS GRIDDLE

399-8535-2 / G32920 PROPANE

1 YEAR LIMITED WARRANTY

ASSEMBLY & USER MANUAL

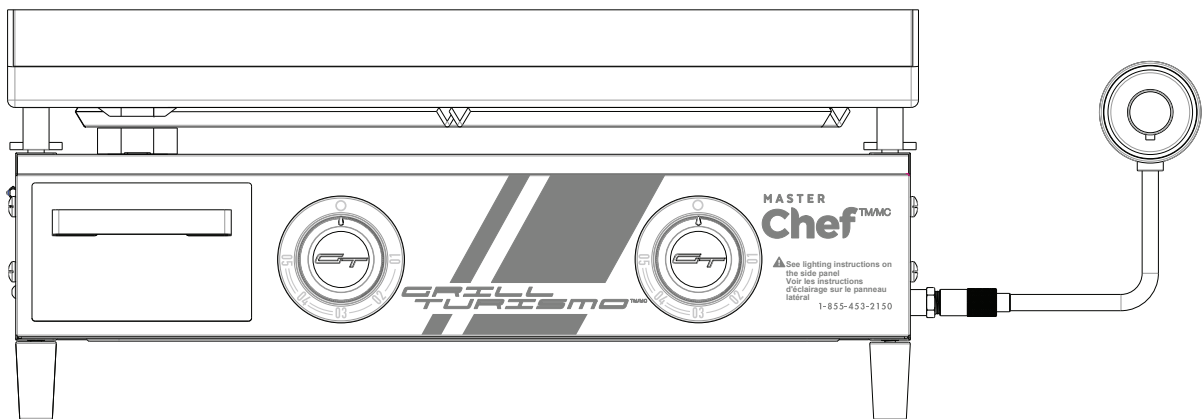

STOP

DO NOT RETURN PRODUCT TO THE STORE

Technicians are available to assist with your product needs. For assembly assistance, technical questions, missing parts or general help, please contact us toll-free

1-855-453-2150

Mon-Fri 9 AM - 7 PM EST, CLOSED Saturday and Sunday

**READ AND SAVE MANUAL FOR FUTURE REFERENCE.
ASSEMBLE YOUR GRILL IMMEDIATELY.**

Missing or damaged parts claims must be submitted within 30 days of purchase date. For product inquiries, parts, warranty and troubleshooting support, please call 1-855-453-2150.



ANS Z21.89-2017 / CSA 1.18-2017
Outdoor Cooking Gas Appliances.



ANS Z21.89-2017 / CSA 1.18-2017
Outdoor Cooking Gas Appliances.

MASTER NO. 21164B

VERSION: JAN.24.2022-WZ



TABLE OF CONTENTS



INSTALLATION AND WARNINGS	4
<hr/>	
SETUP	
Where to set up your 22" Griddle	6
Levelling your 22" Griddle	
<hr/>	
GAS HOOK-UPS AND WARNINGS	
(LP) Liquid Petroleum Gas	6
LP cylinder requirements	
LP cylinder removal, transport and storage	
<hr/>	
SAFETY REGULATOR ASSEMBLY AND WARNINGS	7
<hr/>	
ASSEMBLY INSTRUCTIONS	8
<hr/>	
LEAK TESTING	15
<hr/>	
LIGHTING INSTRUCTIONS	17
<hr/>	
SHUT DOWN PROCEDURE	18
<hr/>	
PREVENTION	19
<hr/>	
CLEANING AND MAINTENANCE:	
Cleaning your Griddle	21
Seasoning your Griddle	22
Storing your Griddle	23
<hr/>	
START GRILLING	25
<hr/>	
TROUBLESHOOTING	26
<hr/>	
WARRANTY AND SERVICE	29

INSTALLATION

INSTALLATION:

The installation must conform with local codes or, in the absence of local codes, with either the national fuel gas code, ANSI Z 223.1/NFPA 54, Natural gas and propane installation code, CSA B149.1, or propane storage and handling code, B149.2.

SAFETY

General safety information is presented on this page and is also located throughout these instructions. Particular attention should be paid to information accompanied by the safety alert symbol “ **DANGER**”, “ **WARNING**”, “ **CAUTION**”.

WARNING

FAILURE TO FOLLOW ALL OF THE MANUFACTURER'S INSTRUCTIONS COULD RESULT IN HAZARDOUS FIRES, EXPLOSIONS, PROPERTY DAMAGE, OR SERIOUS PERSONAL INJURY OR EVEN DEATH.

CAUTION

MAJOR CAUSES OF FIRE ARE POOR MAINTENANCE AND A FAILURE TO MAINTAIN REQUIRED CLEARANCES TO COMBUSTIBLE MATERIALS. IT IS OF UTMOST IMPORTANCE THAT THIS PRODUCT BE INSTALLED ONLY IN ACCORDANCE WITH THESE INSTRUCTIONS.

DANGER

- NEVER LEAVE THIS PRODUCT UNATTENDED WHILE IN OPERATION.
- WHEN COOKING, ALWAYS HAVE A FIRE EXTINGUISHER READY AND AVAILABLE.

CAUTION

- DO NOT TOUCH HOT SURFACES.
- USE HEAT-RESISTANT GLOVES, LONG HANDLED TONGS OR COOKING MITTS AT ALL TIMES, SINCE THE GRIDDLE WILL BECOME VERY HOT.
- SOME PARTS MAY CONTAIN SHARP EDGES, ESPECIALLY AS NOTED IN THE MANUAL. WEAR PROTECTIVE GLOVES DURING ASSEMBLY AND USAGE OF THIS APPLIANCE.
- IN DIRECT SUN, AND IN OPERATION, YOUR GRIDDLE'S SURFACES AND PARTS WILL BECOME VERY HOT. WEAR PROTECTIVE GLOVES TO AVOID BURNS.
- NEVER LEAVE GRIDDLE UNATTENDED WHEN HOT OR IN USE.
- KEEP OUT OF REACH OF CHILDREN AND PETS.
- NEVER USE THE GRIDDLE WITHOUT THE GREASE CUP INSTALLED. WITHOUT THE GREASE CUP, HOT GREASE AND DEBRIS COULD LEAK DOWNWARD AND PRODUCE A FIRE HAZARD.

DANGER

IF YOU SMELL GAS:

1. SHUT OFF GAS TO THE APPLIANCE.
2. EXTINGUISH ANY OPEN FLAME.
3. OPEN LID
4. IF ODOUR CONTINUES, KEEP AWAY FROM THE APPLIANCE AND IMMEDIATELY CALL YOUR GAS SUPPLIER OR FIRE DEPARTMENT.

FAILURE TO FOLLOW THIS INSTRUCTIONS COULD RESULT IN FIRE OR EXPLOSIONS WHICH COULD CAUSE PROPERTY DAMAGE, PERSONAL INJURY OR DEATH

WARNING

1. DO NOT STORE OR USE GASOLINE OR OTHER FLAMMABLE LIQUIDS OR VAPOURS IN THE VICINITY OF THIS OR ANY OTHER APPLIANCE.
2. AN LP CYLINDER NOT CONNECTED FOR USE SHALL NOT BE STORED IN THE VICINITY OF THIS APPLIANCE.

WARNING

DO NOT ATTEMPT TO REPAIR OR ALTER THE REGULATOR OR VALVE ASSEMBLY FOR ANY ASSUMED DEFECT OR FOR ANY TYPE OF RETRO FIT OR CONVERSION. ANY MODIFICATIONS TO THIS ASSEMBLY WILL VOID YOUR WARRANTY AND CREATE THE RISK OF A GAS LEAK AND FIRE. USE ONLY AUTHORIZED REPLACEMENT PARTS SUPPLIED BY THE MANUFACTURER, FOR YOUR MODEL.

ADDITIONAL WARNINGS

DANGER

- NEVER OPERATE THIS APPLIANCE UNATTENDED.
 - NEVER OPERATE THIS APPLIANCE WITHIN 10 FT(3.0M) OF ANY STRUCTURE, COMBUSTIBLE MATERIAL OR OTHER GAS CYLINDER.
 - NEVER OPERATE THIS APPLIANCE WITHIN 25 FT(7.5M) OF ANY FLAMMABLE LIQUID.
 - IF A FIRE SHOULD OCCUR, KEEP AWAY FROM THE APPLIANCE AND IMMEDIATELY CALL THE FIRE DEPARTMENT.
- FAILURE TO FOLLOW THIS INSTRUCTIONS COULD RESULT IN FIRE OR EXPLOSIONS WHICH COULD CAUSE PROPERTY DAMAGE, PERSONAL INJURY OR DEATH.
- THIS INSTRUCTION MANUAL CONTAINS IMPORTANT INFORMATION NECESSARY FOR THE PROPER ASSEMBLY AND SAFE USE OF THE APPLIANCE.
 - READ AND FOLLOW ALL WARNINGS AND INSTRUCTIONS BEFORE ASSEMBLING AND USING THE APPLIANCE.
 - FOLLOW ALL WARNINGS AND INSTRUCTIONS WHEN USING THE APPLIANCE.
 - KEEP THIS MANUAL FOR FUTURE REFERENCE.

CARBON MONOXIDE HAZARD

 THIS GRIDDLE IS A COMBUSTION APPLIANCE. ALL COMBUSTION APPLIANCES PRODUCE CARBON MONOXIDE (CO) DURING THE COMBUSTION PROCESS. THIS PRODUCT IS DESIGNED TO PRODUCE EXTREMELY MINUTE, NON-HAZARDOUS AMOUNTS OF CO IF USED AND MAINTAINED IN ACCORDANCE WITH ALL WARNINGS AND INSTRUCTIONS. DO NOT BLOCK AIR FLOW INTO OR OUT OF THE GRIDDLE.

 CARBON MONOXIDE (CO) POISONING PRODUCES FLU-LIKE SYMPTOMS, WATERY EYES, HEADACHES, DIZZINESS, FATIGUE AND POSSIBLY DEATH. YOU CAN'T SEE IT AND YOU CAN'T SMELL IT. IT'S AN INVISIBLE KILLER. IF THESE SYMPTOMS ARE PRESENT DURING OPERATION OF THIS PRODUCT GET FRESH AIR IMMEDIATELY!

 NEVER USE INSIDE A HOUSE, CAMPER, TENT, VEHICLE OR OTHER UNVENTILATED OR ENCLOSED SPACE. THIS STOVE CONSUMES AIR (OXYGEN) AND PRODUCES CARBON MONOXIDE (CO). DO NOT USE IN UNVENTILATED OR ENCLOSED AREAS TO AVOID ENDANGERING YOUR LIFE.

 NEVER STORE PROPANE NEAR HIGH HEAT, OPEN FLAMES, PILOT LIGHTS, DIRECT SUNLIGHT, OTHER IGNITION SOURCES OR WHERE TEMPERATURES EXCEED 120°F (49°C).

 THIS PRODUCT IS FUELED BY PROPANE GAS. PROPANE GAS IS INVISIBLE, ODOURLESS, AND FLAMMABLE. AN ODORANT IS NORMALLY ADDED TO HELP DETECT LEAKS AND CAN BE DESCRIBED AS A "ROTTEN EGG" SMELL. THE ODORANT CAN FADE OVER TIME SO LEAKING GAS IS NOT ALWAYS DETECTABLE BY SMELL ALONE.

 PROPANE IS HEAVIER THAN AIR AND CAN ACCUMULATE IN LOW PLACES. IF YOU SMELL GAS, TURN THE GRIDDLE OFF AND PERFORM A LEAK TEST ON THE TANK AND CONNECTIONS TO CORRECT THE LEAK.

 DURING LIGHTING AND OPERATION, THIS PRODUCT CAN BE A SOURCE OF IGNITION. NEVER USE THE GRIDDLE IN SPACES THAT CONTAIN OR MAY CONTAIN VOLATILE OR AIRBORNE COMBUSTIBLES, OR PRODUCTS SUCH AS GASOLINE, SOLVENTS, PAINT THINNER, DUST PARTICLES OR UNKNOWN CHEMICALS.

 PROPANE GAS IS HEAVIER THAN AIR AND LEAKING PROPANE WILL SINK TO THE LOWEST LEVEL POSSIBLE. IT CAN IGNITE BY IGNITION SOURCES INCLUDING MATCHES, LIGHTERS, SPARKS OR OPEN FLAMES OF ANY KIND MANY FEET AWAY FROM THE ORIGINAL LEAK. USE ONLY PROPANE GAS SET UP FOR VAPOUR WITHDRAWAL.

SET UP

SETTING UP YOUR GRILL TURISMO™ 22" PORTABLE GRIDDLE

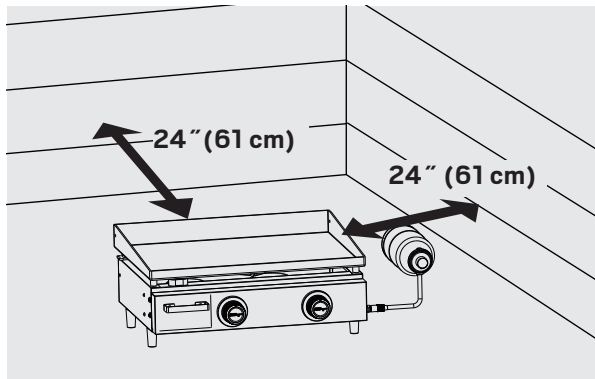

⚠ WARNING

FOR OUTDOOR USE ONLY, IN A WELL-VENTILATED AREA. MINIMUM CLEARANCE TO ADJACENT COMBUSTIBLE MATERIALS IS REQUIRED. GRIDDLE MUST HAVE A CLEARANCE OF 24" (61 CM) ON ALL SIDES FROM A DWELLING, WALLS, ALUMINUM SIDING, WINDOWS, FENCING AND ANY OTHER COMBUSTIBLE MATERIAL.

- Must not be under any overhang, siding or other combustible material.
- Not for use on any boat or recreational vehicle.
- Do not use in enclosed spaces such as a carport, garage, porch, or covered patio.
- Do not block ventilation holes on the sides or back of the unit.
- Avoid setting up in windy locations.
- Keep your griddle in an area clear and free from combustible materials, gasoline and other flammable vapours and liquids.

⚠ CAUTION

THIS APPLIANCE WILL BE HOT DURING AND AFTER USE.

GAS HOOK-UP AND WARNINGS:

(LP) LIQUID PETROLEUM GAS:

- LP gas is non-toxic, odourless and colourless when produced. For your safety, LP gas has been given an odour (similar to rotten cabbage) so that it can be smelled.
- LP gas is highly flammable and may ignite unexpectedly when mixed with air.

LP CYLINDER REQUIREMENTS:

- Propane models are designed for use with a standard 1 lb LP cylinder, not included with griddle. Never connect your griddle to an LP cylinder that exceeds this capacity.
- LP cylinder must be constructed and marked in accordance with the specifications for LP cylinder, U.S. Department of Transportation (DOT) or the National Standard of Canada, CAN/CSA-B339, Cylinders, Spheres and Tubes for the Transportation of Dangerous Goods, CAN/CSA-B339.
- Only cylinders marked "propane" should be used.

NOTE: The regulator may make a humming or whistling noise during operation. This will not affect safety or use of griddle.

GAS HOOK-UP AND WARNINGS:

DANGER

- NEVER STORE A SPARE LP CYLINDER NEAR THE APPLIANCE.
- DO NOT STORE AN LP CYLINDER IN AN AREA WHERE CHILDREN PLAY.
- LP CYLINDER SHOULD ONLY BE STORED OUTSIDE AND IN A COOL DRY PLACE.
- NEVER EXPOSE THE CYLINDER TO DIRECT SUNLIGHT OR EXCESSIVE HEAT.
- IF YOU SEE, SMELL OR HEAR GAS ESCAPING, IMMEDIATELY GET AWAY FROM THE LP CYLINDER/APPLIANCE AND CALL YOUR FIRE DEPARTMENT.

WARNING

IF THE INFORMATION ABOVE IS NOT COMPLETELY ADHERED TO, A FIRE/EXPLOSION CAUSING DEATH, SERIOUS INJURY OR PROPERTY DAMAGE MAY OCCUR.

SAFETY HOSE AND REGULATOR

Your griddle is designed to operate on LP gas at a pressure of 2.74 kPa (11" water column). A pressure regulator pre-set to this pressure is supplied with your griddle.

Any attempt to connect a regulator to any connections other than the included connector could result in fires, explosions, injuries or property damage.

WARNING

THIS GRILL TURISMO™ 22" PORTABLE GAS GRIDDLE IS SOLD PROPANE READY TO BE USED WITH 1LB/ 16 OZ LP PROPANE CYLINDER ONLY.

ANY ATTEMPT TO CONVERT THIS GRIDDLE TO A NATURAL GAS OR A 20 LB PROPANE TANK WILL VOID THE MANUFACTURER'S WARRANTY.

WARNING

- IN THE EVENT OF RAIN, SNOW, HAIL, SLEET, OR OTHER FORMS OF PRECIPITATION WHILE COOKING WITH OIL OR GREASE, COVER THE COOKING VESSEL IMMEDIATELY AND TURN OFF THE APPLIANCE BURNERS AND GAS SUPPLY. DO NOT ATTEMPT TO MOVE THE APPLIANCE OR COOKING VESSEL.
- THIS APPLIANCE IS NOT INTENDED FOR AND SHOULD NEVER BE USED AS A HEATER.
- THE CYLINDER BE DISCONNECTED WHEN THE APPLIANCE IS NOT IN USE.
- THE PRESSURE REGULATOR ASSEMBLY SUPPLIED WITH THE APPLIANCE MUST BE USED. REPLACEMENT PRESSURE REGULATORS ASSEMBLIES SHALL BE THOSE SPECIFIED BY THE APPLIANCE MANUFACTURER.
- THE CYLINDER SUPPLY SYSTEM MUST BE ARRANGED FOR VAPOR WITHDRAWAL.

MASTER
Chef^{TM/MC}

**GRILL
TURISMO**^{TM/MC}

**22" (55.9 CM) PORTABLE
GAS GRIDDLE**

399-8535-2 / G32920 PROPANE

ASSEMBLY INSTRUCTIONS

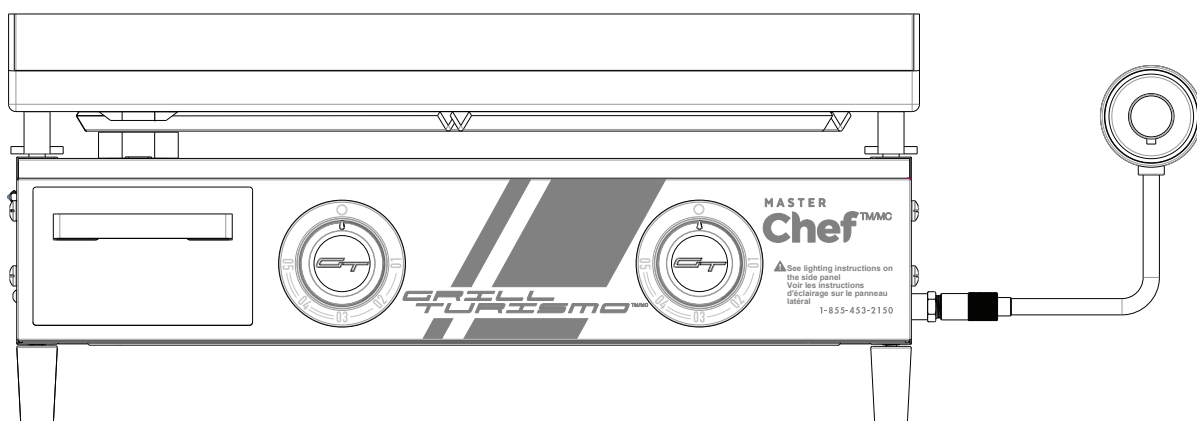

PARTS LIST

Item No.	Qty.	Description	Part No.
AA	1	Griddle Top	G329-1200-01
AB	2	Hex Nut	G329-1101-01
BA	1	Burner Box Assembly	G329-0200-01
BB	4	Burner Box Feet	G329-0102-01
BC	2	Burner	G329-0400-01
BD	2	Electrode Set	G329-0301-01
BE	1	Match Holder	G329-0002-01
BF	1	Grease Channel	G329-0003-01
CA	1	Control Panel	G329-1600-01
CB	1	Mainfold Assembly	G329-0700-01
CC	1	Regulator	G329-0502-01
CD	2	Control Knob Bezel	G453-0092-010
CE	2	Control Knob	G364-3600-01
CF	1	Grease Cup	G329-1700-01
CG	1	Safety Cover	G329-0501-01
D1	1	Assembly and User Manual	G329-M001-01

EXPLODED PARTS

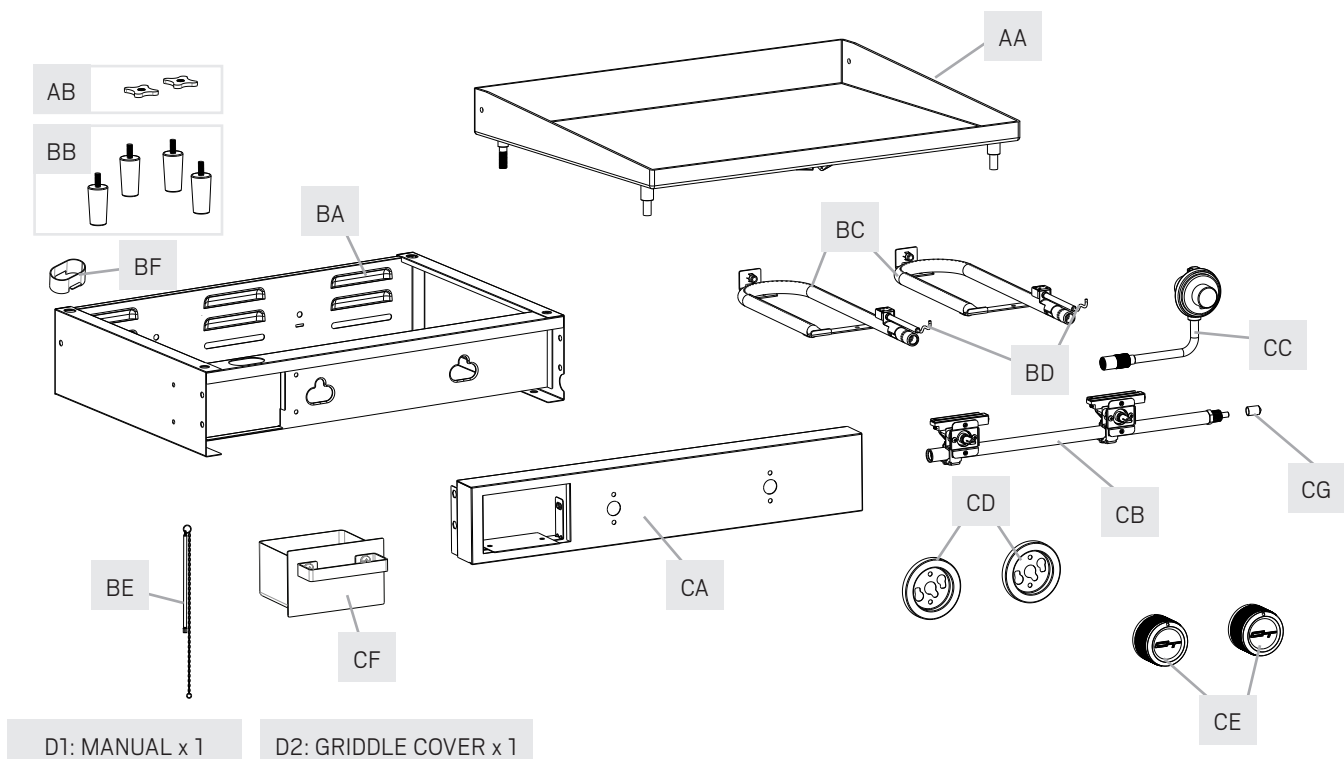

STEP 1

BB  x 4

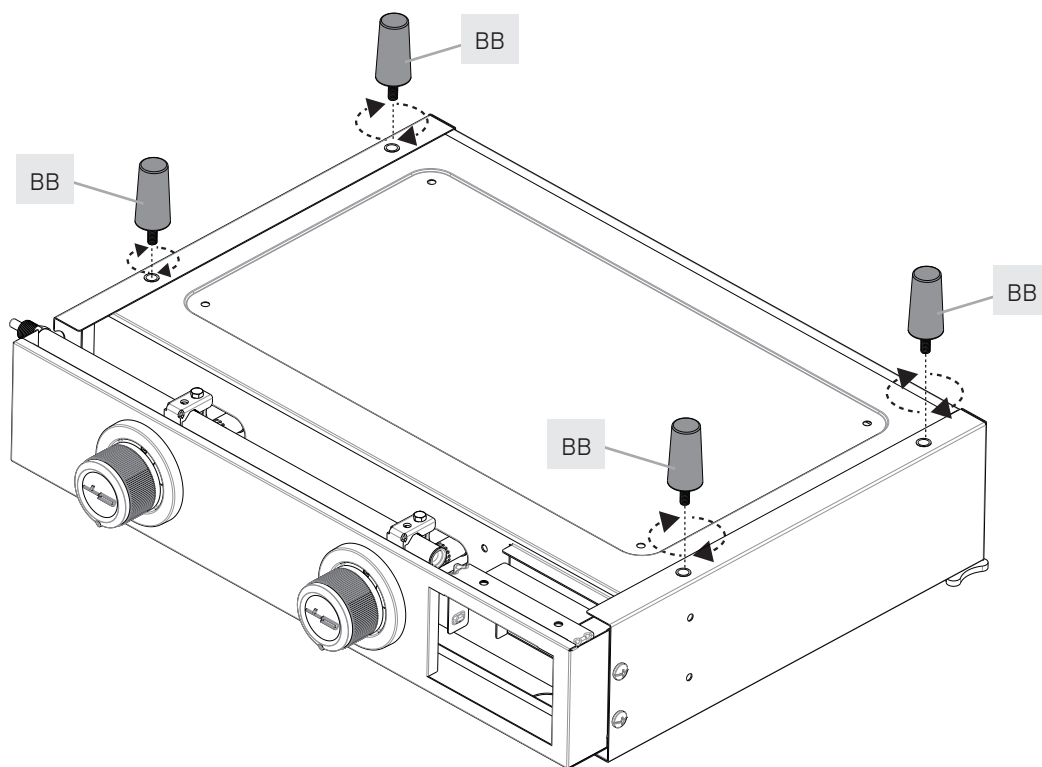

STEP 2

AB  x 2

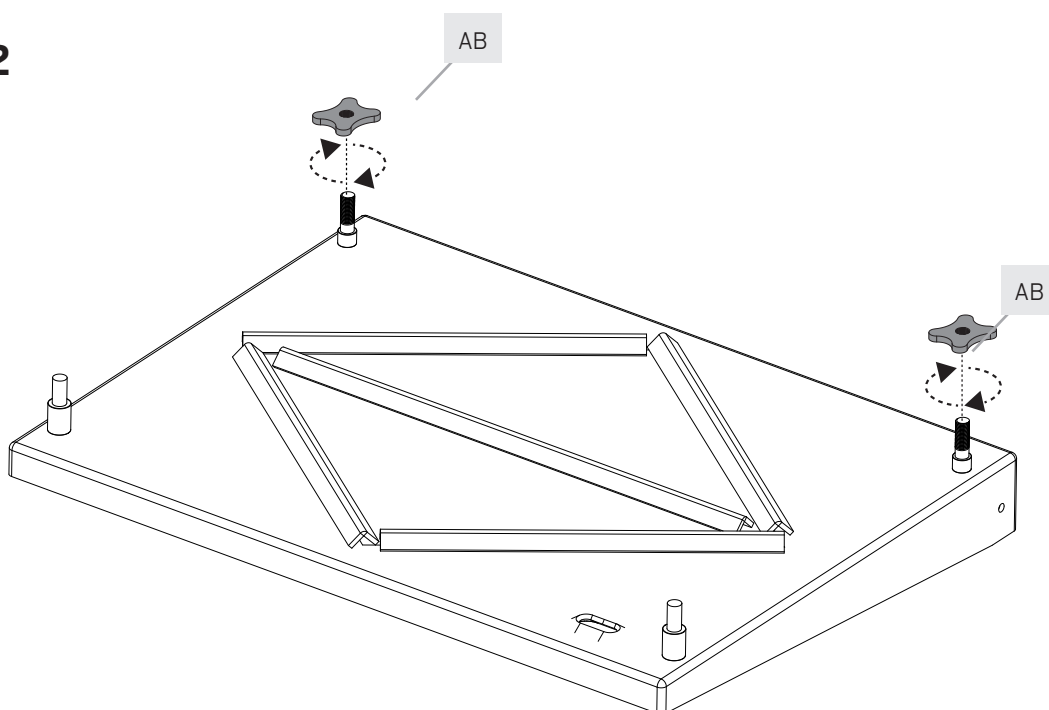

STEP 3-A

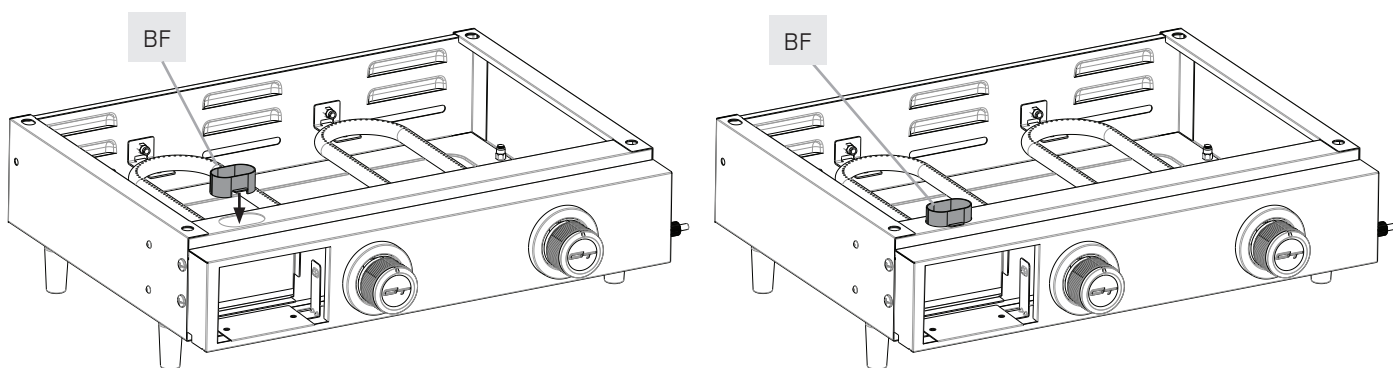
BF  x1

STEP 3-B

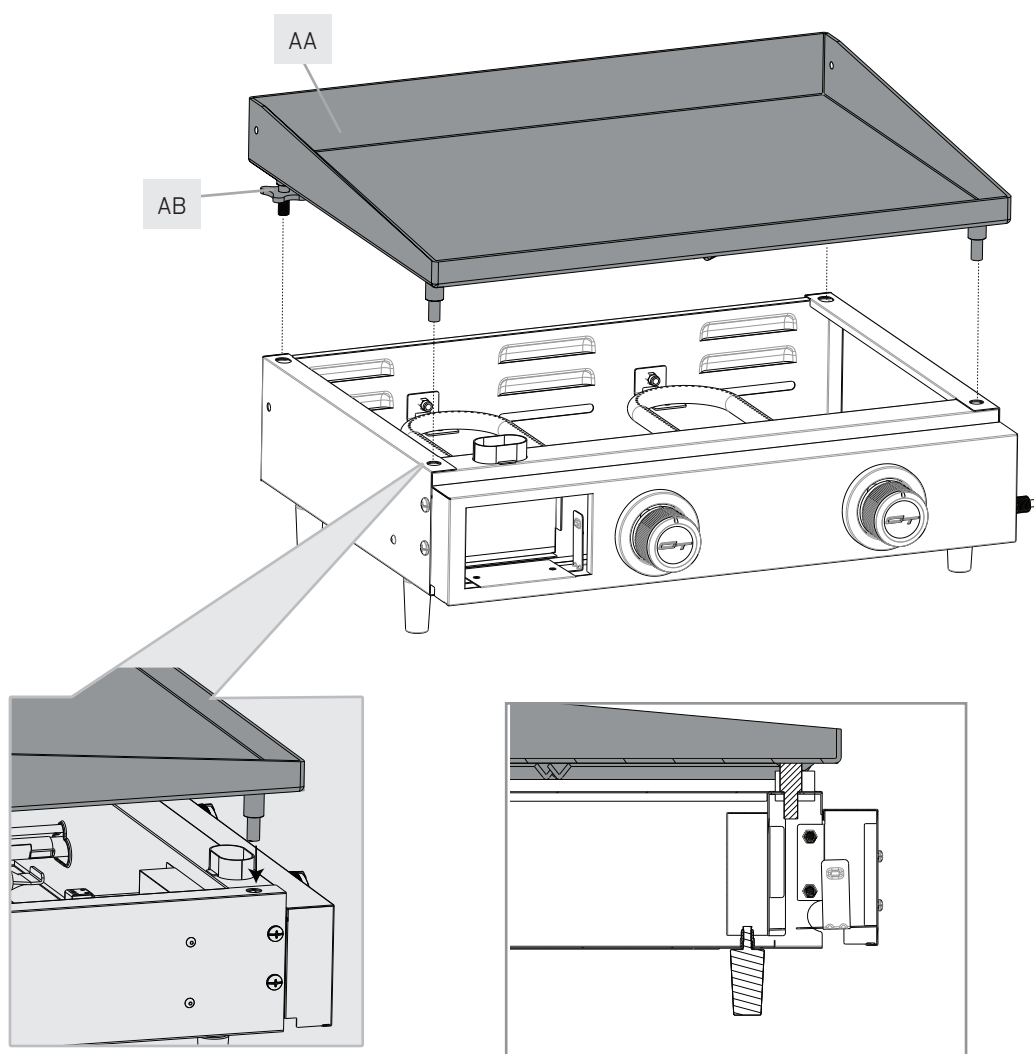

STEP 4

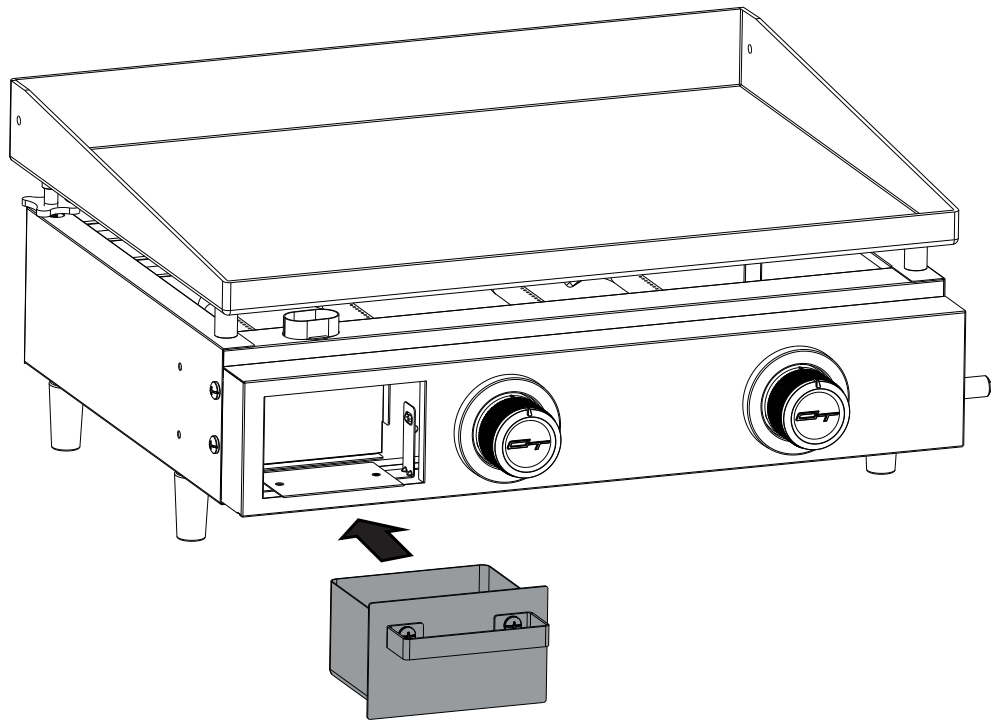

STEP 5

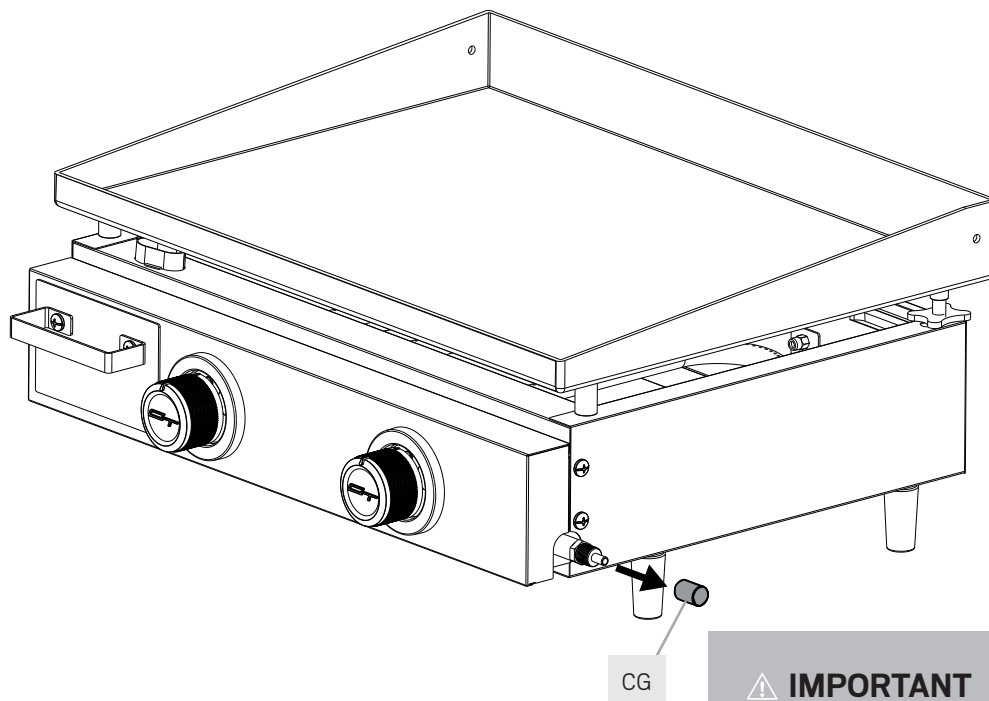

⚠ IMPORTANT
DO NOT DISCARD THE SAFETY COVER.

STEP 6

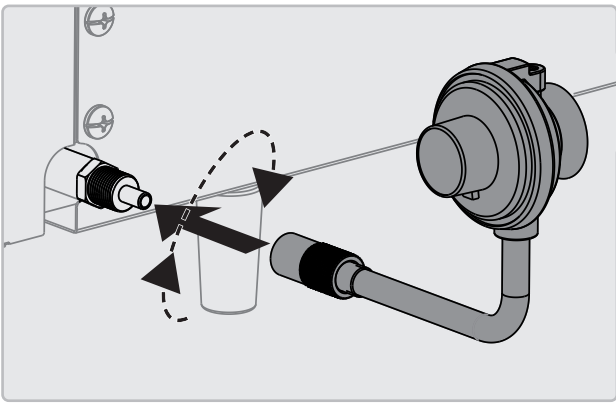
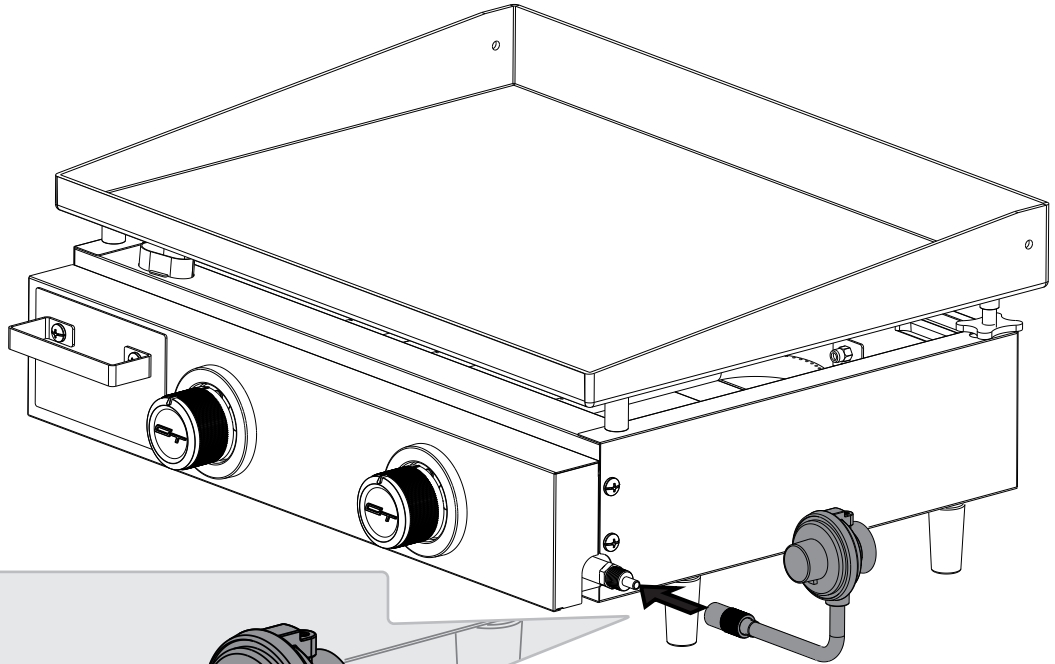

⚠ NOTE
THE 1 LB PROPANE
CYLINDER IS SOLD
SEPARATELY.

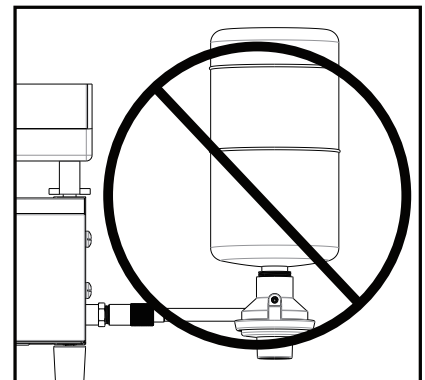
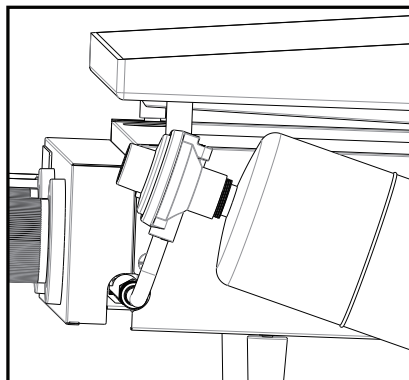
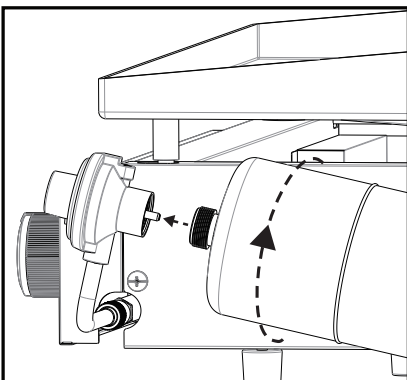
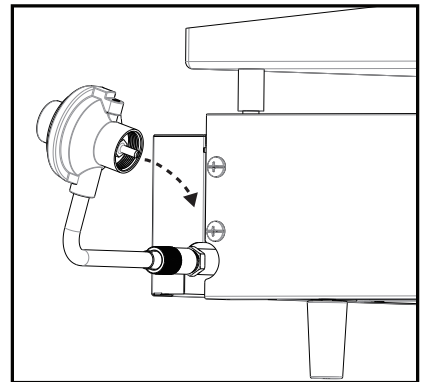
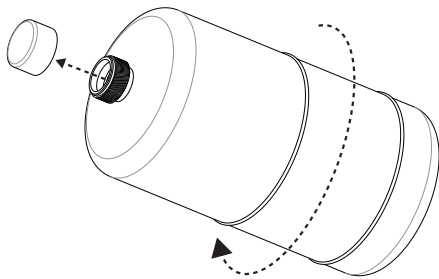

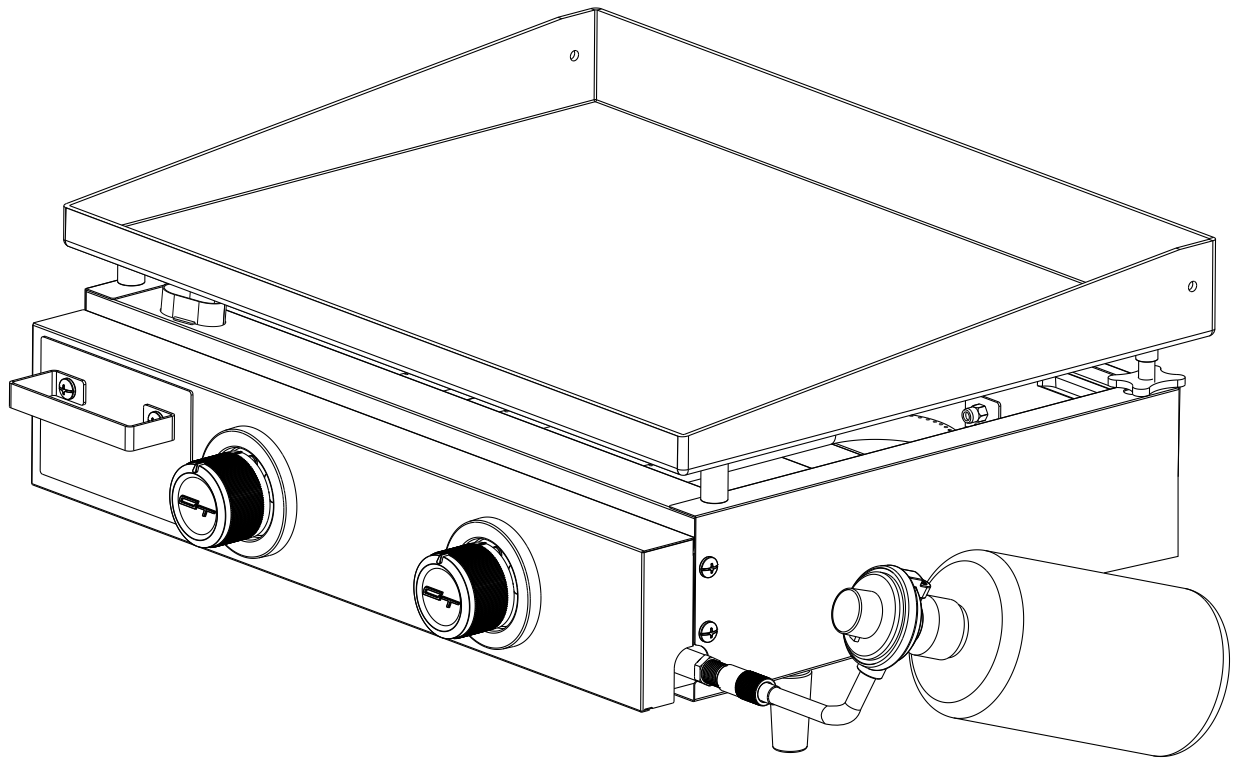

⚠ WARNING

NEVER OPERATE GRIDDLE WITH PROPANE CYLINDER IN AN INVERTED POSITION.

LEAK CHECK

LEAK CHECK PROCEDURE

A leak test is used to determine the integrity of a seal. Before using your gas griddle, perform a leak test on the connection between the regulator and the gas cylinder to reduce the risk of serious bodily injury or death from fire or explosion.

A leak test should be performed:

- Before starting your griddle for the first time.
- Every time the gas cylinder has been changed.
- After travel, especially over rough or bumpy roads.
- After a prolonged period of storage or non-use.

⚠ ATTENTION

- ALWAYS PERFORM AND LEAK CHECK OUTDOORS IN A WELL-VENTILATED AREA, AWAY FROM IGNITION SOURCE.
- ENSURE THE GRIDDLE IS NOT IN USE AND COOL TO THE TOUCH.
- DO NOT SMOKE DURING A LEAK TEST.
- DO NOT USE AN OPEN FLAME TO CHECK FOR GAS LEAKS.

HOW TO PERFORM A LEAK CHECK

1. Mix a solution of one part water and one part dish soap in a spray bottle.
2. Spray the solution onto the connection between the regulator and the gas cylinder and look for bubbles to form, which will indicate a gas leak, defect or damaged connection.

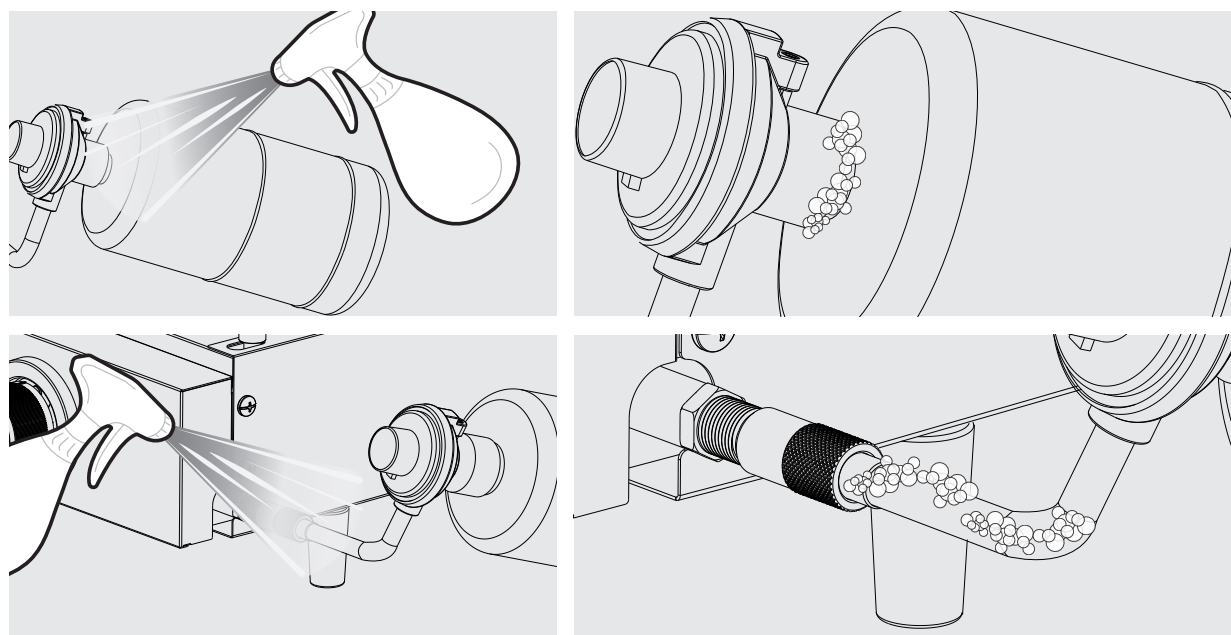

⚠ ATTENTION

IF A LEAK WAS FOUND, RETIGHTEN AND INSPECT CONNECTIONS. IF A LEAK CANNOT BE STOPPED, CONTACT THE MASTER CHEF® CUSTOMER CARE HOTLINE FOR ASSISTANCE 1-855-453-2150.

LEVELLING YOUR GRIDDLE

LEVELLING YOUR GRIDDLE

Levelling your griddle will ensure proper flow of grease in the grease channel and into the awaiting grease cup. Now that you have chosen a location for your griddle, you will need to adjust the levelling feet on the bottom of griddle assembly to encourage the flow of grease to the proper location.

⚠ ATTENTION

ONLY ADJUST THE LEVELING FEET WHEN YOU HAVE YOUR GRIDDLE IN POSITION AND WHEN THE GRIDDLE IS COOL.

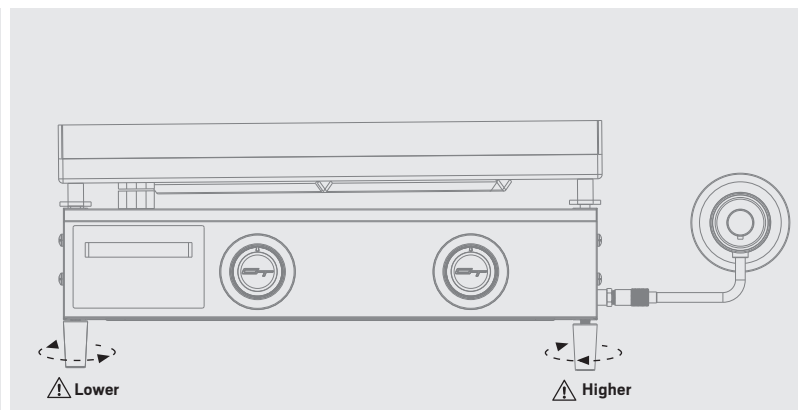
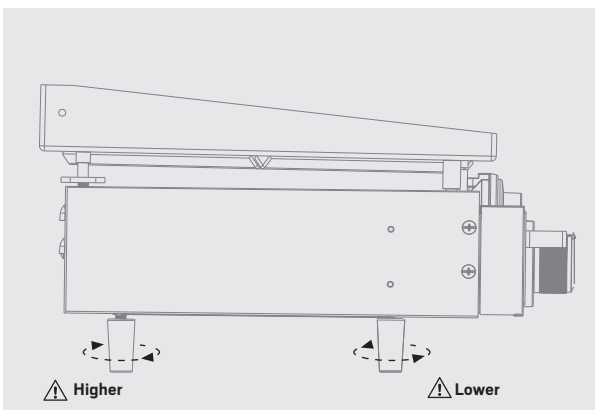

LIGHTING INSTRUCTIONS

LIGHTING INSTRUCTIONS

1. Set your griddle on a sturdy flat surface and confirm that all control knobs are in the "0" / "OFF" position.



2. Select a burner control knob. Push in and turn the control knob counter-clockwise to the "05" / "MAX" position. You will hear a "click" sound as the piezo starter is activated in the control knob. Confirm that the burner is lit before continuing.



⚠ ATTENTION

IF IGNITION FAILS, INSERT A BBQ LIGHTER OR MATCH THROUGH THE SIDE OF THE BURNER BOX, AS SHOWN BELLOW.

3. Repeat step 2 to light the second burner. Confirm that the burner is lit before performing a burn-off (see page 18).

⚠ WARNING

NEVER STAND WITH YOUR HEAD DIRECTLY OVER THE GRIDDLE WHEN PREPARING TO LIGHT THE MAIN BURNERS, TO PREVENT POSSIBLE BODILY INJURY. MULTIPLE TRIES AT RELIGHTING BURNERS COULD RESULT IN A BUILD-UP OF GAS AND A FLASH OF FLAMES. IF YOU ARE HAVING TROUBLE LIGHTING, SEE THE TROUBLESHOOTING SECTION OF THIS MANUAL.

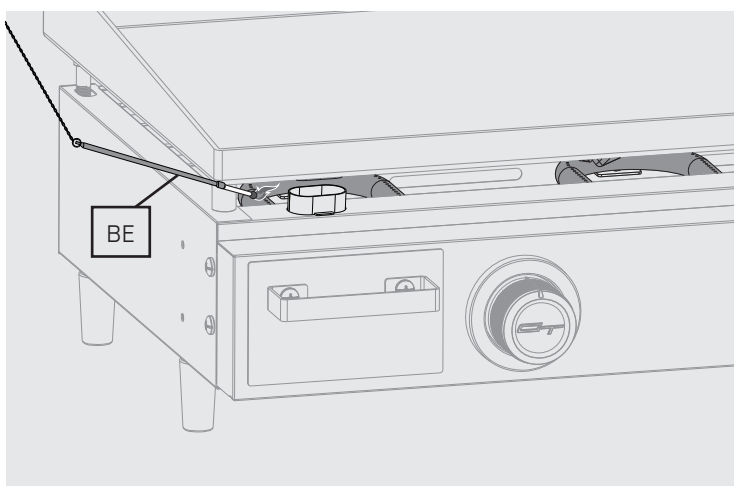

⚠ ATTENTION

ALWAYS PREHEAT THE GRIDDLE BEFORE STARTING TO COOK. LIGHT ALL BURNERS AND ADJUST THEM TO THE "05" / "MAX" POSITION FOR 10 MINUTES. FOLLOWING PREHEAT; ADJUST THE CONTROLS TO APPROPRIATE SETTING.

LIGHTING INSTRUCTIONS

PERFORM A BURN-OFF

Before using your griddle for the first time, it is important to complete a burn-off. Start the griddle and operate for a minimum of 15 minutes on "05" / "MAX" to burn off the unit. This will "heat clean" the internal components, dissipate odours and rid it of any foreign matter.

⚠ WARNING

NEVER USE SPIRIT, LIGHTER-FLUID OR KEROSENE FOR LIGHTING OR REFRESHING A FIRE IN YOUR GRIDDLE.

SHUT DOWN PROCEDURE

SHUT DOWN PROCEDURE

1. Push in and turn control knobs clockwise to the "0" / "OFF" position.



⚠ CAUTION

THE GRIDDLE WILL REMAIN HOT FOR SOME TIME. DO NOT ATTEMPT TO RELOCATE OR STORE THE GRIDDLE UNTIL IT HAS COMPLETELY COOLED.

2. Remove propane cylinder from pressure regulator and replace protective cap on cylinder.
3. Disconnect the pressure regulator.

NOTE: A "poof" sound is normal as the last of the LP gas is burned.

⚠ WARNING

IF REGULATOR FROSTS, TURN OFF THE GRIDDLE AND LP CYLINDER VALVE IMMEDIATELY. THIS INDICATES A PROBLEM WITH THE CYLINDER AND IT SHOULD NOT BE USED ON ANY PRODUCT. RETURN CYLINDER TO SUPPLIER!

⚠ WARNING

DO NOT TRANSPORT GRIDDLE WITH GAS CYLINDER ATTACHED. THE CYLINDER MAY LOOSEN OFF THE VALVE AND CAUSE A GAS LEAK, POSSIBLY RESULTING IN AN EXPLOSION, FIRE OR SEVERE BODILY HARM. DISCONNECT GAS CYLINDER FIRST BEFORE TRAVEL OR STORAGE. IF STORING THE GRIDDLE INDOORS, LEAVE THE GAS CYLINDER OUTDOORS.

⚠ WARNING

WHEN TRANSPORTING AND STORING THE CYLINDER, MAKE SURE IT IS IN AN UPRIGHT POSITION AND NOT ON ITS SIDE. DO NOT SMOKE AROUND CYLINDER, ESPECIALLY WHEN TRANSPORTING IN A VEHICLE.

PREVENTION

BURNER FLAME PATTERN

Your griddle's burners are designed to mix oxygen and propane at a rate that allows for optimal flames. Should the burner holes, air shutter or venturi get blocked, it will affect the propane and air mixture, causing low or inconsistent flames or flames coming from the air gate.

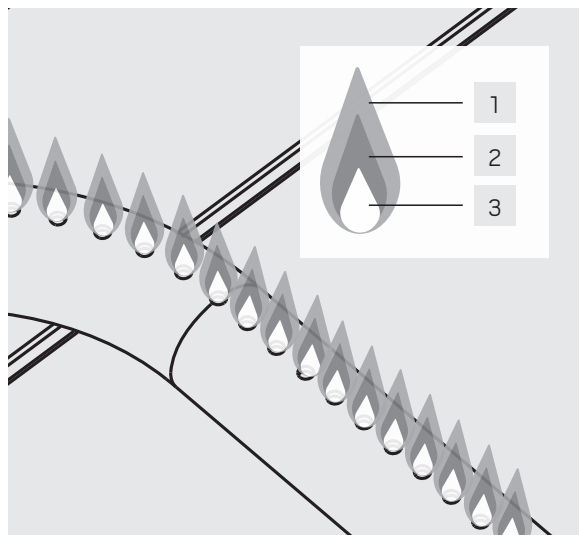

Healthy flames might have a few flickers of yellow colour **1**, then a dark blue colour **2**, followed by a vibrant blue **3** by the burner tube.

GREASE FIRE

Grease fires or excessive flare-ups can occur on the griddle surface, within the burner box or in the grease cup. Do not throw water on a grease fire. Do not try to smother the fire. Baking soda, much like salt, will quickly cut the oxygen to the fire, smothering the flame. Keeping a couple of boxes of baking soda and/or a fire extinguisher in close proximity to your griddle is highly recommended.

PREVENTION

- Removing grease build-up on the griddle surface and inside the burner box.
- Clean out the grease cup after every use.
- Always reduce cooking temperature to the medium setting, following PREHEAT.

FOR YOUR SAFETY

- **DO NOT** throw water on a fire.
- **DO** keep baking soda handy to extinguish a fire.
- **DO** follow all warnings and safety checks outlined in the USER MANUAL.
- **DO** protect your family and home by performing the cleaning and maintenance steps outlined in this manual.

PREVENTION

FLASH-BACK FIRES

Blockages in the burner venturi caused by spiders, insects and nests can cause a flashback fire. A flashback fire occurs when a blockage in the venturi tubes caused by spiders, insects and nests blocks the flow of gas, forcing it back towards the control panel and control knob. The ignited gas, if not detected, can cause a fire to burn in this area. If you experience any of the characteristics of a flashback fire. Close the control knobs and disconnect the LP Cylinder. Follow the burner cleaning procedure outlined in the maintenance section of this manual.

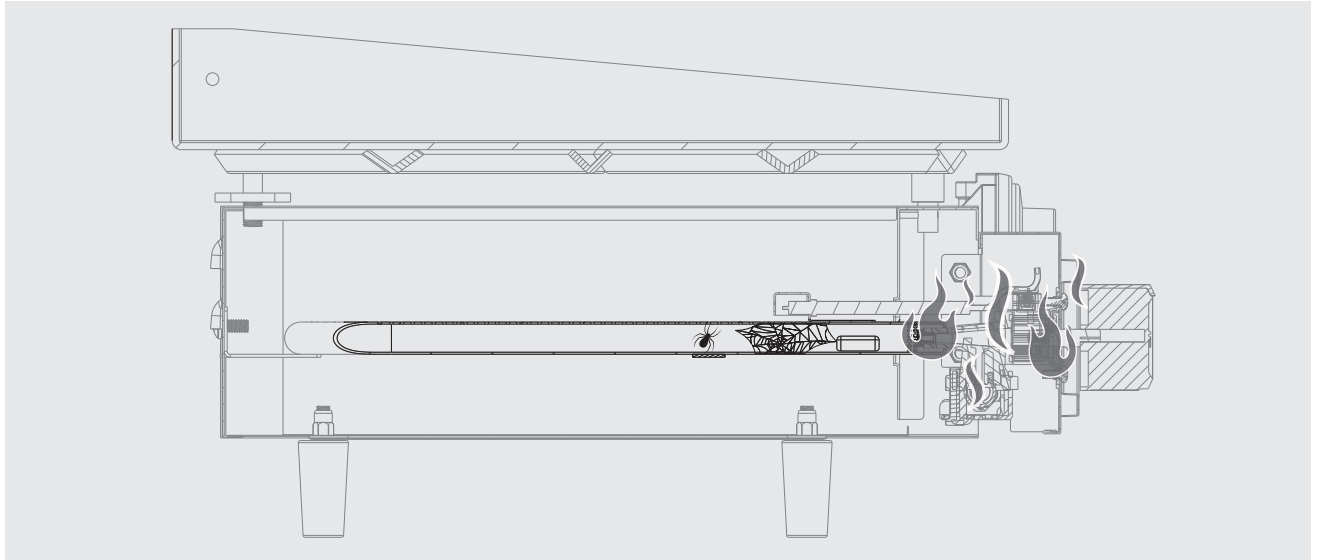

CHARACTERISTICS OF A FLASH-BACK FIRE

- A fire burning between the burner box and control panel, usually accompanied by **HOT OR MELTING CONTROL KNOBS**.
- Burners may burn with **LARGE YELLOW FLAMES**.
- **Burners may not light**.

PREVENTING FLASH-BACK FIRE

1. After lighting, check for normal burner flames.
2. If irregular flames are found, shut down immediately and perform maintenance on burners, to remove blockages.
3. If control knobs appear hot, shut down immediately, and perform maintenance on burners, to remove blockages.
4. Clean tip of valve gas jet to remove any build-up or blockages.
5. It is recommended the griddle be covered with the included surface cover to limit the ability for blockages caused by spiders, insects or nests.

⚠ WARNING

AT FIRST SIGHT OF YELLOW, UNRULY FLAMES OR POORLY LIT BURNERS, SHUT DOWN YOUR GRIDDLE AND REMOVE AND CLEAR OBSTRUCTIONS, LIKE INSECT WEBS FROM THE BURNERS AND VALVE GAS JET.

⚠ CAUTION

ALWAYS ALLOW SUFFICIENT TIME FOR THE GRIDDLE TO COOL FULLY BEFORE HANDLING OR CLEANING ANY OF ITS PARTS.

⚠ WARNING

NEVER APPLY COLD WATER ACROSS THE WHOLE SURFACE OF A HOT GRIDDLE AT ONCE. THIS WILL CAUSE WARPING.

DO NOT USE SOAP ON THE GRIDDLE COOKING SURFACE. THIS WILL DESTROY THE GRIDDLE'S SEASONING.

SEASONING YOUR GRIDDLE TOP

WHAT IS SEASONING

Seasoning is the process of applying multiple coatings of oil to the griddle surface and heating to a high temperature to bake the oil into the griddle top. Seasoning your griddle top improves the cooking performance, creates a non-stick surface for cooking, prevents damage and deterioration due to moisture and humidity and extends the life of your griddle.

PLEASE NOTE:

The Grill Turismo™ 22" Portable Gas Griddle is pre-treated with soy oil as a protective coating. This coating may leave a discolouration on the griddle top. This is normal and will not affect the seasoning process.

RECOMMENDED OILS FOR SEASONING

- a. Vegetable oil
- b. Vegetable shortening
- c. Canola oil
- d. Flax oil
- e. Olive oil – Not ideal. Burns off at lower temperature than the other options above.



OPERATION AND PERFORMANCE

⚠ WARNING

ALWAYS WEAR PROTECTIVE HEAT RESISTANT GLOVES TO AVOID BURNS.

SEASONING

1. Light the griddle and set controls to the "05" / "Max" position.
2. Apply oil to the griddle top, sides and corners, using long handle tongs and paper towels to spread the oil and coat the entire surface thoroughly.

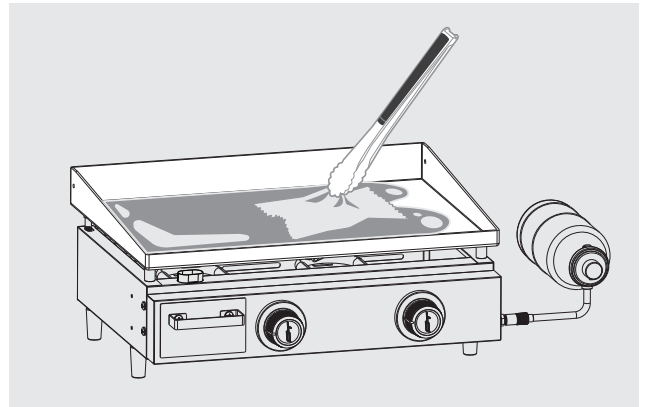
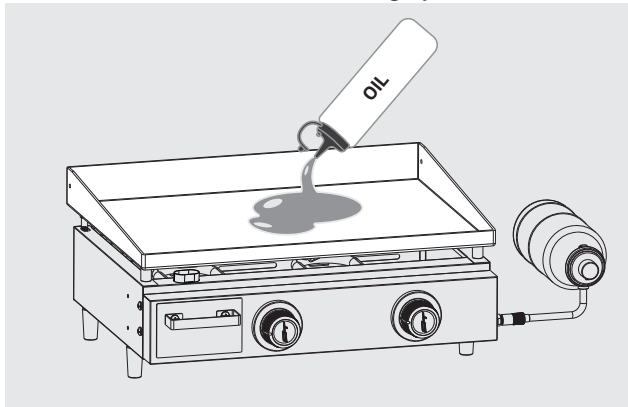

3. Heat the oil to its smoke point. You will notice the griddle top changing colour.
4. When the oil stops smoking, repeat steps 2 to 4, until there is a noticeable sheen on the surface. About 3-5 times, until the griddle surface becomes dark.

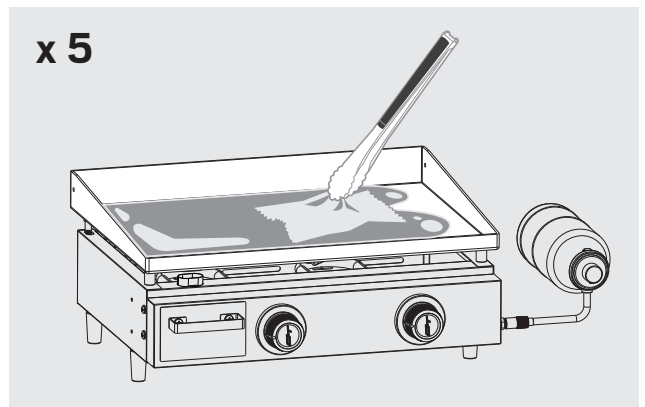
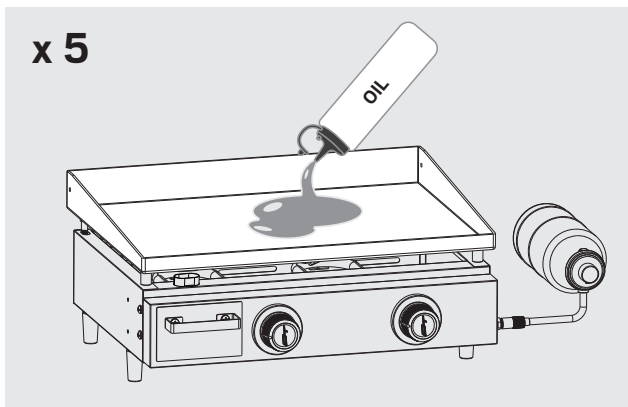

With continued use of your griddle, the seasoning bond will get better and better. Applying a coating of oil at the start and finish of each cook, will help to maintain seasoning. Never use soap to clean the griddle, this will destroy the seasoning. Never pour cold water on a hot griddle surface, as this can cause the griddle top surface to warp.

⚠ ATTENTION

CUSTOMERS IN HUMID OR COASTAL CLIMATES MAY REQUIRE MORE FREQUENT SEASONINGS AND THE USE OF HEAVIER COOKING OILS TO AVOID RUSTING AND CORROSION

WARPING

Small variations in manufacturing and raw materials can cause some griddles to warp slightly during preheat, when applying water to the surface or placing cold food directly on the cook surface. Warping will correct itself after the first 5-10 uses.

CARE AND MAINTENANCE

⚠ WARNING

ALWAYS WEAR PROTECTIVE HEAT-RESISTANT GLOVES TO AVOID BURNS.

CLEANING YOUR GRIDDLE

1. At the end of every cook and before storing your griddle, cool griddle below 300°F (150°C). Scrape any food debris using a spatula or straight metal scraper.
2. Wipe griddle surface with paper towel.

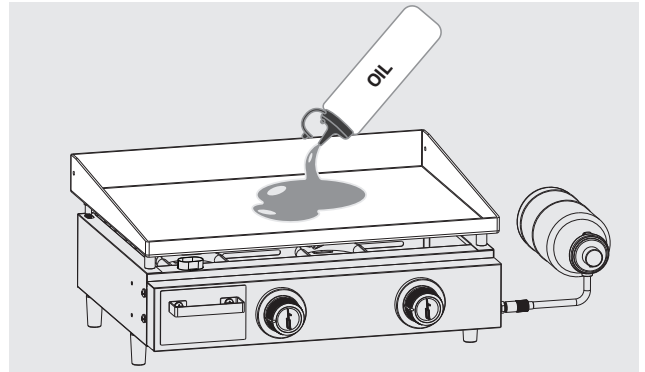
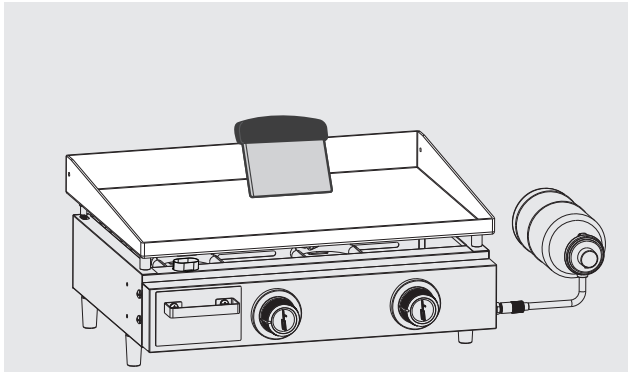

3. For hard-to-remove grease, you can use a tablespoon of water and your scraper to loosen debris and scrape into the grease cup.
4. Apply thin coat of cooking oil to maintain seasoning and protect the griddle top.

STORING YOUR GRIDDLE

- If possible, always store in a cool, dry location.
- Remove the LP cylinder when storing your griddle. Store appliance indoors ONLY if gas supply is turned off, disconnected and removed from appliance and stored outdoors.
- If storing for long periods of time, make sure that the griddle top is fully seasoned and protected.
- Only cover the griddle when the unit is fully cooled.
- Always cover your griddle with an all-weather grill cover, to protect from all elements. It is recommended to tent the grill cover to allow water to drain from the cover instead of sitting on the griddle top.

GRIDDLE SURFACE RUST

The appearance of rust spots on the griddle top is an indication that the protective seasoning has worn off and must be repeated.

Begin by removing the griddle top from the burner box and dampening the surface with water.

With protective gloves and steel wool, scrub the areas of concern until the rust has been lifted from the surface.

Rinse the surface thoroughly. Do not allow griddle to stand in water. Dry thoroughly. Follow the full seasoning steps outlined on page 21.

GREASE CATCH

Remove and clean the grease cup AFTER EVERY USE to prevent possible spillage, grease fires and hot grease splatters.

When the griddle top and grease cup have FULLY COOLED, remove the grease cup and dump the contents into a disposable container and then into the trash. Alternatively, you can place the disposable container into the fridge for the oil to solidify, before throwing into the trash.

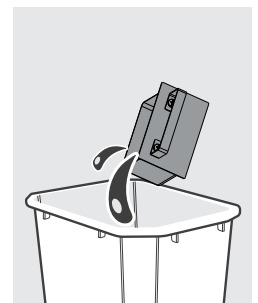
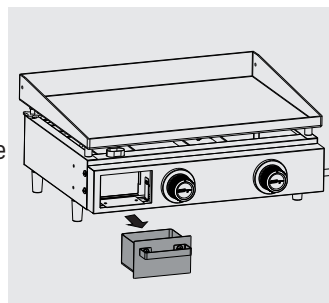

CARE AND MAINTENANCE

BURNERS & BURNER BOX MAINTENANCE

Although your griddle's burner box is fully protected from grease and other build-up that can accumulate during cooking, regular checks of the burners and ignition electrode are still required to ensure proper performance, safety and longevity of your griddle.

BURNER MAINTENANCE

Because the burners are covered by the griddle top, it is not as easy to identify poor performance and premature aging of parts.

For this reason, we recommend that once a season the griddle top is removed and burner maintenance conducted:

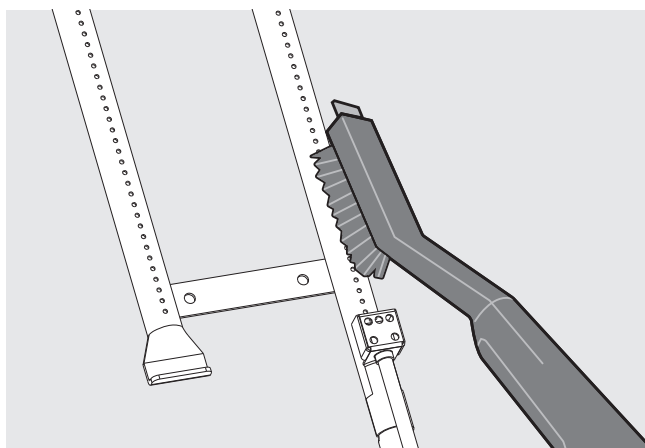
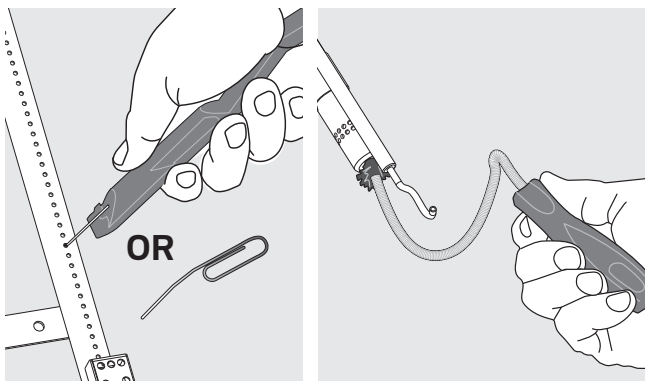
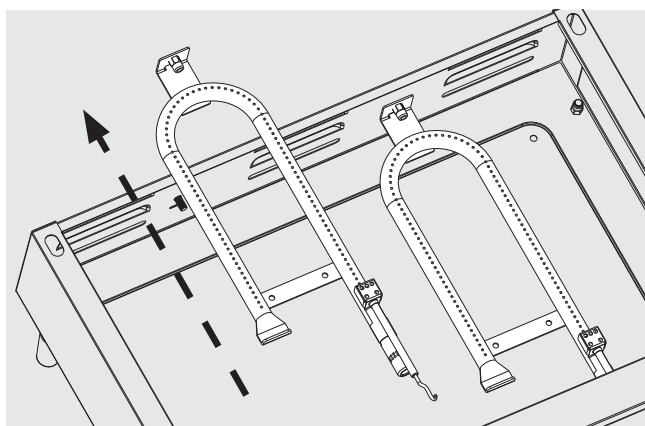

1. Remove griddle top. Place it down right side up.
2. Remove the hardware to free the burners. Use WD40 and a screwdriver to make this removal easier.
3. Remove burners.
4. Use a flexible venturi brush to clean the interior of the burners. Ensure you enter the burner far enough to remove any spider webs and nests that may be present.
5. Use a wire or paper clip to clean any blocked burner ports.
6. Brush away any rust or corrosion from the burners surface, and wipe clean with a damp cloth. Dry the burners.
7. Re-install the burners. Ensure that the burners are properly seated on the valve gas jet before assembling hardware.

NOTE: Before reinstalling burners, use a cotton swab to clean the valve gas jet.

CARE AND MAINTENANCE

GENERAL GRIDDLE SAFETY TIPS

1. ALWAYS turn control knobs and gas supply "OFF" when not in use.
2. Do not leave griddle unattended at any time while in operation.
3. If the griddle surface and components have not been regularly maintained or safety checked, take extreme caution at first lighting, during preheat and when cooking at high temperatures.
4. Never move the griddle while in operation or still hot.
5. All surfaces in and around the griddle can become HOT to the touch. Keep children and pets away. Do not allow people to congregate around the griddle. Always use long-handled barbecue utensils and grilling gloves to avoid burns and protect from grease splatters.
6. The grease cup must be in position before cooking.
7. Always empty the grease cup after every cook. Do not remove the grease cup until it has completely cooled.
8. Clean the griddle often, preferably after each cookout.
9. If you notice grease dripping from the griddle, wait until cool and adjust the level of your griddle top to ensure that grease flows correctly into the grease cup.
10. Perform a leak test every time you change your LP cylinder.
11. Inspect your griddle's hose and regulator for any cracks, tears or damage caused by rodents. If unsure, perform a leak test to ensure your safety and the safety of others around you.
12. If the regulator frosts, turn "OFF" the griddle and LP cylinder valve immediately. This indicates a problem with the cylinder and it should not be used on any product. Return to supplier!
13. Never position any flammable or temperature sensitive item close to the griddle surface, as they may overheat and result in an explosion, fire, severe personal injury or death.
14. Do not use water on a fire. If a fire develops and it is safe to do so, turn the LP cylinder off and disconnect it. Wait for the fire to go out before turning the control knobs "OFF".

WARNING

DO NOT ATTEMPT TO REPAIR OR ALTER THE HOSE, VALVE OR REGULATOR FOR ANY ASSUMED DEFECT OR FOR ANY TYPE OF RETRO FIT OR CONVERSION. ANY MODIFICATIONS TO THIS ASSEMBLY WILL VOID YOUR WARRANTY AND CREATE THE RISK OF A GAS LEAK AND FIRE. USE ONLY AUTHORIZED REPLACEMENT PARTS SUPPLIED BY THE MANUFACTURER FOR YOUR MODEL.

START GRILLING

WARNING

ALWAYS OBSERVE SAFE FOOD HANDLING AND SAFE FOOD PREPARATION PRACTICES WHEN USING THIS GRIDDLE, TO PREVENT FOOD-BORNE ILLNESSES.

AAFC* Safe Minimum Internal Temperatures

Fish	145° F
Pork	160° F
Egg Dishes	160° F
Steaks and Roasts of Beef, Veal or Lamb	145° F
Ground Beef, Veal or Lamb	160° F
Whole Poultry (Turkey, Chicken, Duck, etc.)	165° F
Ground or Pieces of Poultry (Chicken Breast, etc.)	165° F

*For more information visit foodsafety.gov

TROUBLE SHOOTING

PROBLEM	IDENTIFYING THE CAUSE	SOLUTION
Burner will not light (can ignite with a match)	Electrode misaligned.	Electrode should be positioned 1/8" to 1/4" (4 to 7 mm) away from the burner tube.
	Electrode ceramic piece is damaged.	Replace electrode.
	Faulty ignition.	Contact customer support.
Burner will not light (cannot ignite with a match)	Burners are not properly seated over valve orifices. Gas not safely entering the burner tube.	Check burners to ensure that they are seated on the valves correctly.
	Positive connection not made between regulator and the propane cylinder.	Check all connections between the regulator and propane cylinder. Ensure a proper seal before retrying.
	Low or out of propane.	Change propane cylinder and try again.
Burner flames are yellow or irregular	Blockage in the burner venturi, disrupting the air/gas mixture in the burner.	Clean the burner to remove any obstructions, including but not limited to spider webs. If your burners have bug shields, clean any spider webs, soot, or debris off the bug shield.
Fire behind control panel- Hot or melting control knobs	Blockage in the burner venturi, not allowing propane to flow through the burner, forcing flame back towards the control panel (Flash-back fire).	Clean the burner to remove any obstructions including spider webs.
	Burner is improperly seated on gas valve.	Check burners to ensure that they are seated on the valves correctly.

TROUBLE SHOOTING

PROBLEM	IDENTIFYING THE CAUSE	SOLUTION
Low or incomplete flame and difficulty lighting both burners (assuming burners and venturi tubes are free and clear of blockages)	All griddle regulators contain a flow limiting device for consumer safety. This device measures the amount of propane going through the regulator to ensure the levels are safe. If the flow rate through the regulator is too high (a symptom of a large leak), the flow limiting device will be triggered, restricting the flow of propane to reduce the chance of a dangerous fire. This safety system can accidentally be tripped by turning on a control knob too quickly or connecting the propane cylinder when a burner control knob has been on.	This safety system can be reset by turning the control knobs to the "OFF" position, closing the propane cylinder and disconnecting the propane cylinder from the regulator. Wait five minutes to allow the pressure to dissipate. Ensure the control knobs are "OFF" before reconnecting the propane cylinder to the regulator. Follow proper lighting procedure.
	Propane cylinder is empty or low.	Refill or replace the propane cylinder.
	Regulator stuck in safety position.	Reset the safety by turning the control knobs "OFF". Remove the propane cylinder and pressure regulator. Check the connections for damage before reconnecting the pressure regulator and propane cylinder. Follow proper lighting procedure.
Flame blows out on "LOW"	Flow limiting device in regulator has been activated due either to a leak or improper lighting.	Perform a leak test before resetting the pressure regulator.
	Low or out of propane.	Replace propane cylinder.
	High wind condition.	Adjust griddle to shield from wind.
	Burner is improperly seated on gas jet.	Ensure burners are correctly assembled and seated on the gas valve.
Decreasing heat, "popping sound"	Out of propane.	Replace propane cylinder.
	Burner and/or burner tubes are blocked.	Clean the burners.
	Regulator flow limiting device activated either by improper lighting, turning on control knobs too quickly, or a poor connection between the griddle and the propane cylinder.	Reset the pressure regulator.
Humming noise coming from regulator	Cylinder valve opened too quickly.	N/A
	This is not a defect. It is caused by internal vibrations in the regulator and does not affect performance or safety of the griddle.	



WARNING

HOT SURFACE

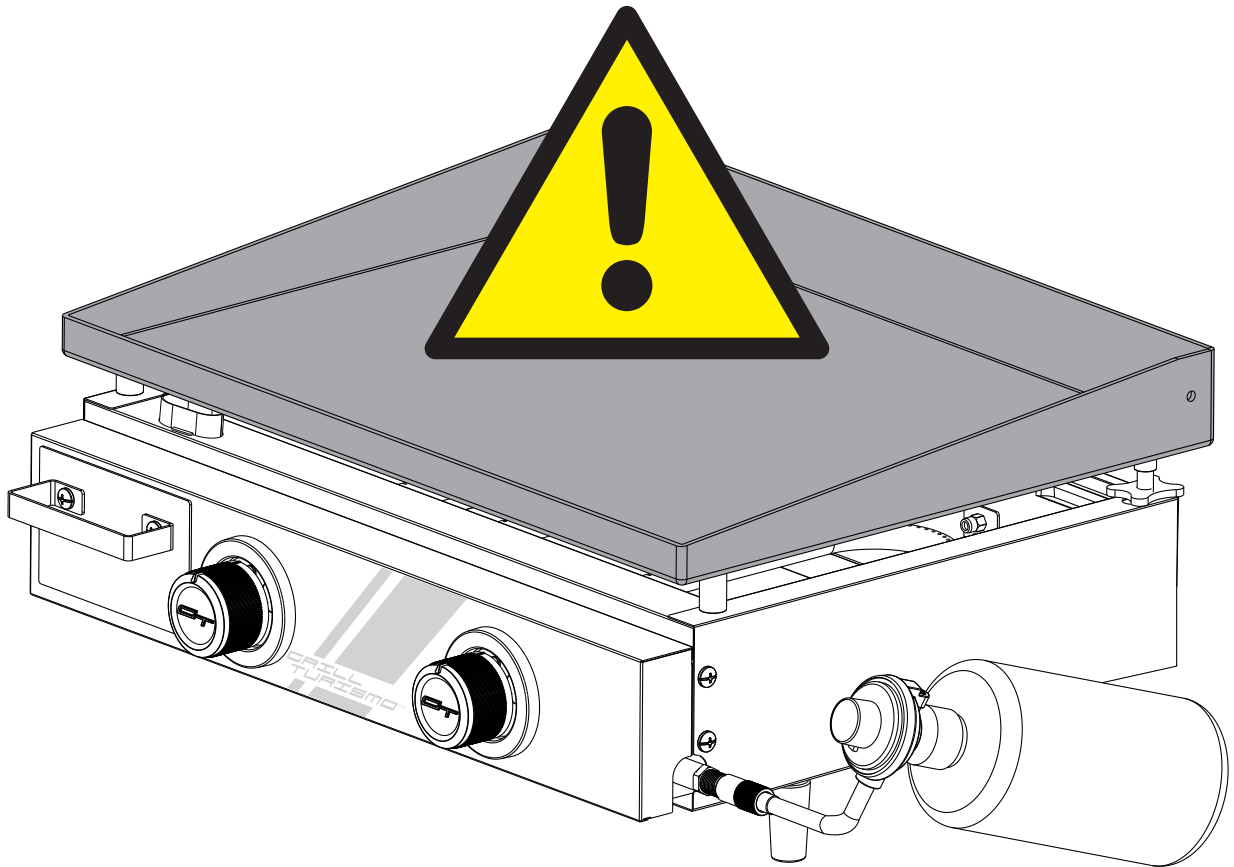

CAUTION

- AVOID BURNS.
- DO NOT TOUCH WHEN GRIDDLE IS IN USE.
- EXTREMELY HOT SURFACE.
- ALWAYS WEAR PROTECTIVE HEAT RESISTANT GLOVES TO AVOID BURNS.

* SHADED AREAS BECOME EXTREMELY HOT WHEN IN USE.

WARRANTY AND SERVICE

BEFORE YOU CALL FOR SERVICE have the following information available:

1. **Serial number:** Located on the CSA rating label.
2. **Model number:** The model number is located on the front cover of this manual and the bottom right corner of the rating label.
3. **Proof of purchase** by the original owner.

Call the Customer Care Hotline 1-855-453-2150
HOURS: 9AM- 7PM EST Mon-Fri, Closed Saturday and Sunday

IF YOUR PRODUCT IS DAMAGED:

1. Call the **Master Chef® Customer Care** Hotline **1-855-453-2150**.
2. DO NOT return to the store for replacement of damaged or defective parts. Master Chef® Customer Care will ensure that all in-stock replacement parts arrive at your home within 3-10 business days.
3. Concealed Loss or Damage: If damage is unnoticed until merchandise is unpackaged, resolve issue by contacting Master Chef Customer Care immediately. Missing or damaged parts should be claimed within 30 days of purchase.

**To ensure your satisfaction and for follow-up service,
register your barbecue online at www.masterchefbbqs.com**

LIMITED WARRANTY:

Trileaf Distribution®, hereby warrants to the ORIGINAL PURCHASER of this Master Chef® Barbecue that it will be free of defects in workmanship, for a Limited 1 year from the date of purchase, as follows:

Please see Limitations and Exclusions section on page 30.

LIMITED 1 YEAR: ALL PARTS

CAUTION

Some parts may contain sharp edges—especially as noted in the manual! Wear protective gloves if necessary. For residential use ONLY. Do not use for commercial cooking.

WARRANTY AND SERVICE

LIMITATION AND EXCLUSIONS

Trileaf Distribution® has the following limitations to its warranty:

1. This limited warranty is non-transferable and becomes void if used for commercial or rental purposes.
2. This warranty applies only when griddle is used in Canada.
3. Warranty is in lieu of all warranties, expressed or implied, and all other obligations or liabilities related to the sale or use of its grill products.
4. Trileaf Distribution® shall not be liable for incidental, consequential, special or contingent damages resulting from its breach of this written warranty or any implied warranty.
5. Trileaf Distribution® will repair or replace parts, at its option, proven defective under normal use and service and which on examination during the applicable warranty period (see exclusions to warranty coverage below).
6. Shipping and handling charges are the responsibility of the original consumer-purchaser for all in/out of warranty part orders.
7. This limited warranty will not reimburse you for the cost of any inconvenience, food, personal injury or property damage.
8. Trileaf Distribution® does not authorize any person or company to assume for it any other obligation or liability in connection with the sale, installation, use, removal, return, or replacement of its equipment; and no such representations are binding on Trileaf Distribution®.
9. Visit www.masterchefbbqs.com to register your product on line. The purchaser shall retain a copy of the purchase invoice for future claims.

Trileaf Distribution excludes from its warranty the following:

- a. Accidental damage, abuse, tampering or misuse, misapplication, vandalism, careless handling.
- b. Damages caused by improper assembly or installation, alteration, failure to follow proper usage, safety and maintenance instructions presented throughout this manual, including, improper clearance to combustible materials.
- c. Failure to perform regular maintenance, safety checks and service, including but not limited to removal of ash and grease buildup from the burner pot and other components, resulting in damage caused by grease fires and flare-up fires.
- d. Part failure due to lack of cleaning and maintenance, use of improper cleaning products, such as indoor cleaners, abrasive and chemical cleaners, porcelain oven cleaner and other chemical cleaners which can cause damage to surfaces.
- e. Normal wear and tear, chipping and scratching on painted or porcelain enamel surfaces, dents, discolouration caused by environment or heat, surface corrosion, rust or rust perforation, chemical exposure in the atmosphere and other damages which result with normal use and are otherwise uncontrollable by the manufacturer.

There are no other express warranties except as set forth herein and any applicable implied warranties of merchantability and fitness are limited in duration to the period of coverage of this express written limited warranty.

To ensure your satisfaction
and for follow-up service, register your griddle online at:

www.masterchefbbqs.com

Made in China
Imported by Trileaf Distribution Trifeuil
Toronto, Canada
M4S 2B8

MASTER
Chef TM/MC

www.masterchefbbqs.com

Customer support: 1-855-453-2150

